

Plastic Filters

Durable high quality Plastic filters for wide range of filtration applications



flow rates

**up to 50 m³/h
(220 US gpm)**

filtration degrees

3500-22 micron

diameters

¾" - 3"

max. operating pressure

1.5 bar (22 psi)

features:

- Interchangeable filter elements for wide range of flow rates, multiple filtration degrees and applications
- Excellent mechanical strength, corrosion resistance for chemical compatibility
- Low pressure loss
- Easy to install and maintain, no tools required for rinsing
- Available with exclusive features for semi-automatic cleaning
- Wide range of applications for the irrigation, municipal and industrial markets

Amiad Plastic Filters

General

With a variety of filter elements, Amiad all purpose plastic filters are made for wide range of filtering applications, filtration degrees, and are easy to install and maintain. They are constructed from high quality engineered-plastic materials providing excellent mechanical strength, durability and chemical resistance.

Amiad plastic filters need no tools for dismantling or removing the filter element from the filter housing for rinsing; Visual monitoring the status of the filter element without disrupting the water flow is easily done with Amiad's innovative clogging indicator connected to the filter's pressure check points.

Amiad plastic filters can be upgraded to semi-automatic operation by adding one of Amiad's exclusive Brushaway or Scanaway assemblies.

Filter Elements

Amiad supplies a variety of filter elements for its plastic filters that cover a wide range of flow rates, filtration degrees and applications.

Screen Elements: (1)

These screen elements are constructed of molded plastic ribs that support a stainless steel weave-wire or weaved nylon screen for filtration degrees of 800 to 22 micron.

Perforated Stainless Steel Elements: (2)

Suitable for coarse filtration (straining) between 3,500 and 800 micron.

Disc Elements: (3)

The disc elements are designed for effective removal of organic substances. The elements are constructed using engineered plastic discs that are stacked onto a telescopic core.

The discs are grooved on both sides and intersect to form the filtration element when compressed.

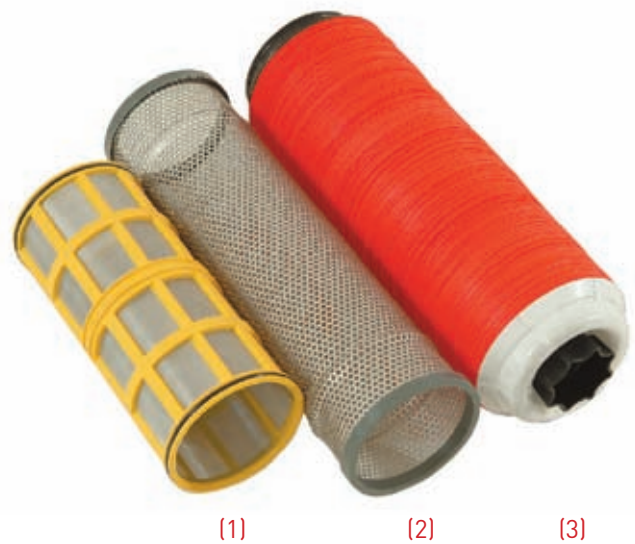

The effective filtration area is comprised of both the outside surface and the channels formed by the intersecting grooves. Suspended organic particles adhere to the grooved surface adding depth to the filtration process.

Cleaning the disc element is made simple by the unique design of the telescopic core which allows the discs to separate during the cleaning process while maintaining perfect sealing when the element is in the filter housing.

Filtration Degrees Available

The following table lists the various filter elements of Amiad's Plastic Filters line and the optional filtration degrees for each filter element. For ease of operation and maintenance the filter elements are color coded. Please consult your dealer for the most suitable filter element for your application requirements.

Color	Brown	Green	Orange	Black	Yellow	Red	Purple	White	Brown	Blue	Green	Gray			
Micron	22	25	50	80	100	130	180	200	250	300	500	800	1500	2500	3500
Mesh	450	450	300	200	155	120	80	75	60	50	30	20	10	6	4
¾", 1"C	■		■▲	■▲	■▲	■▲		■▲		■▲	■▲	■			
1"S, 1½"C, 1½"S	■	★	■▲	■▲	■▲	■▲★		■▲	★	■▲	■▲	■			
2", 3"			▲	▲	▲★	▲★	★	▲	★	▲	▲	●	●	●	●

■ Nylon Screen ▲ Weave Wire Screen ★ Disc Element ● Perforated Screen

2”T

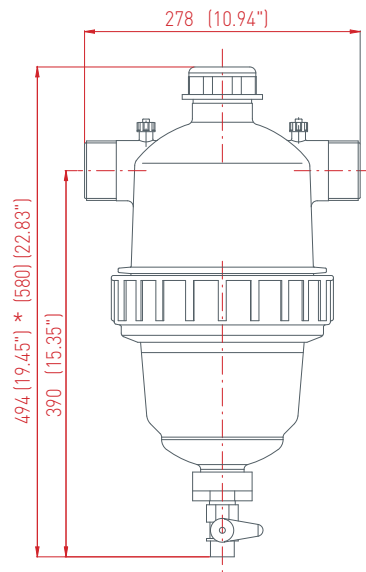

Pressure Loss Graphs

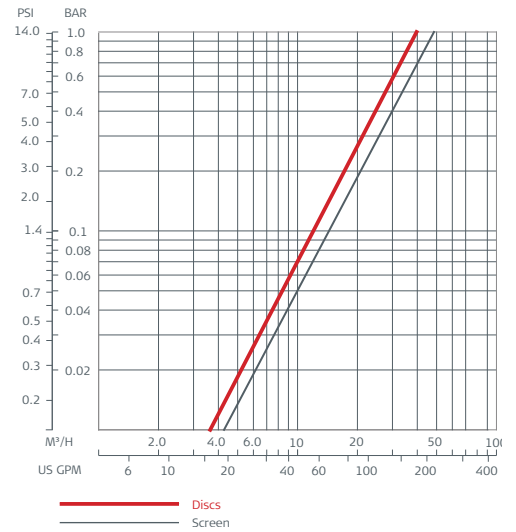

2”T Super

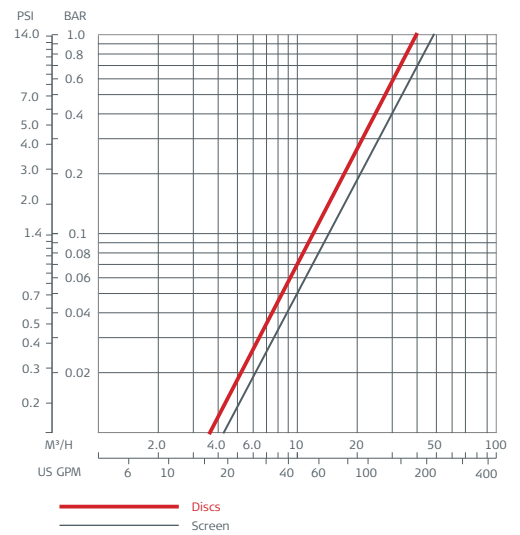
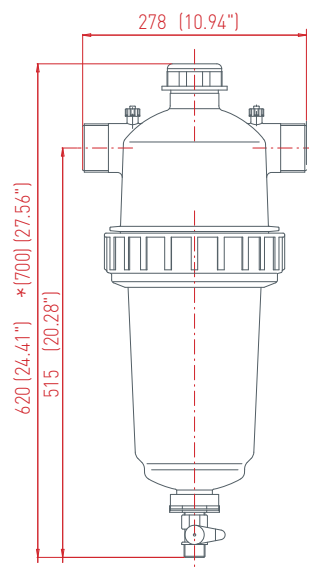

Dim. in mm (inch)

*Approx. length required for maintenance

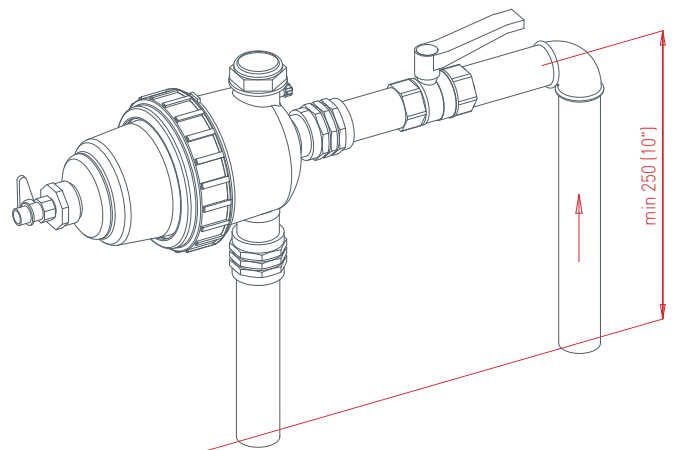
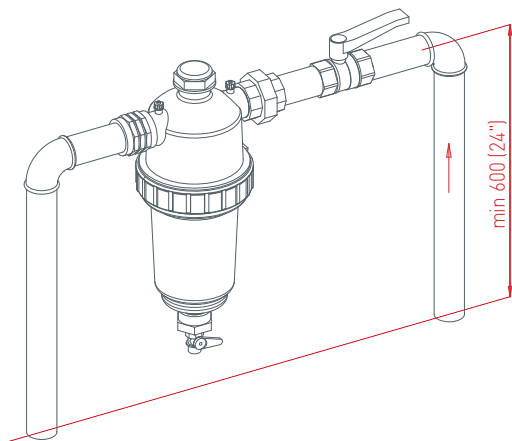
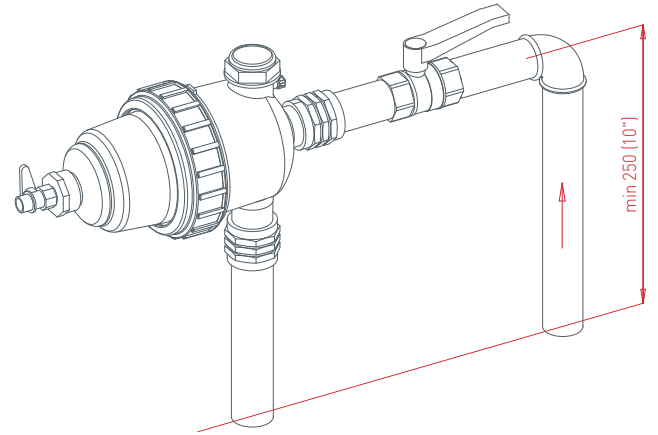
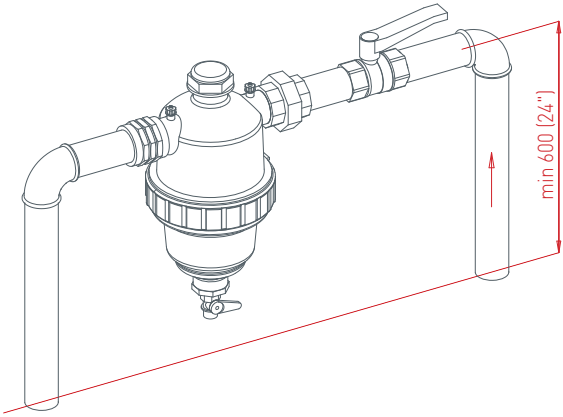

Dim. in mm (inch)

3" TL

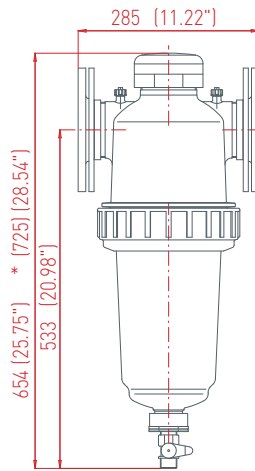

Pressure Loss Graphs

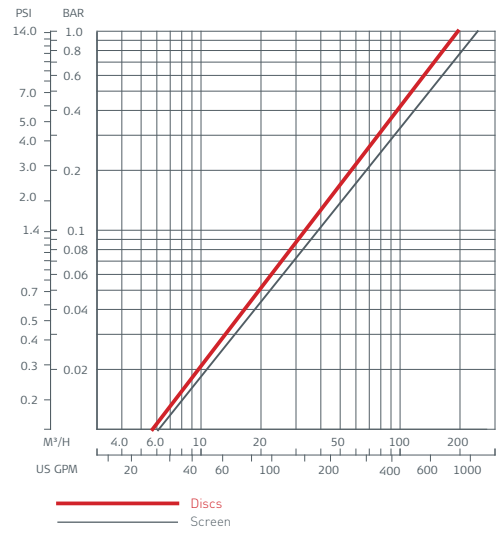

3"LT-S

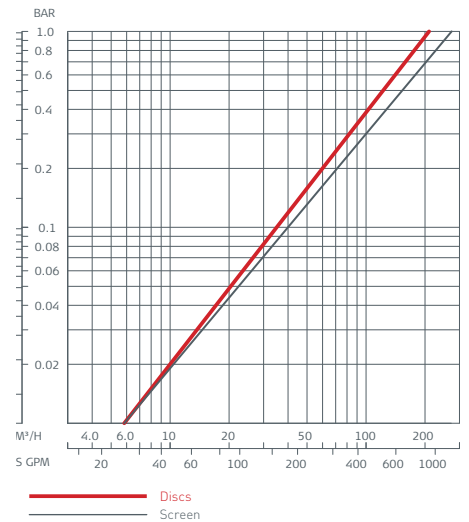

Technical Specifications

Filter Type	2" T	2" T-S	3" TL	3" LT-S
-------------	------	--------	-------	---------

General Data				
Maximum flow rate*	25 m ³ /h (110 US gpm)	25 m ³ /h (110 US gpm)	50 m ³ /h (220 US gpm)	50 m ³ /h (220 US gpm)
Inlet/Outlet diameter	2" (50 mm)	2" (50 mm)	3" (80 mm)	3" (80 mm)
Standard filtration degrees	3500, 2500, 1500, 800, 500, 300, 250, 200, 130, 100, 80, 50 micron			
Max. working pressure	10 bar (145 psi)			
Max. working temperature	60°C (140°F)			
Weight [empty]	Screen = 3.6 kg (7.9 lb) Discs = 4.4 kg (9.7 lb)	Screen = 4.2 kg (9.2 lb) Discs = 5.4 kg (11.9 lb)	Screen = 4.5 kg (9.9 lb) Discs = 5.7 kg (12.5 lb)	Screen = 9.2 kg (20.2 lb) Discs = 11 kg (24.2 lb)

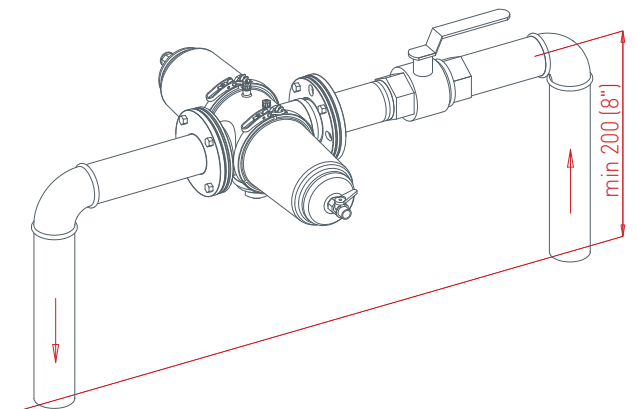
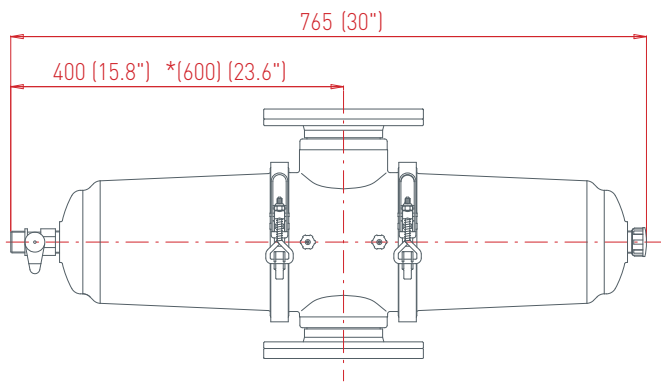
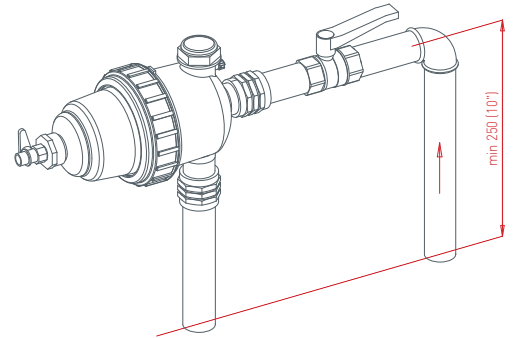
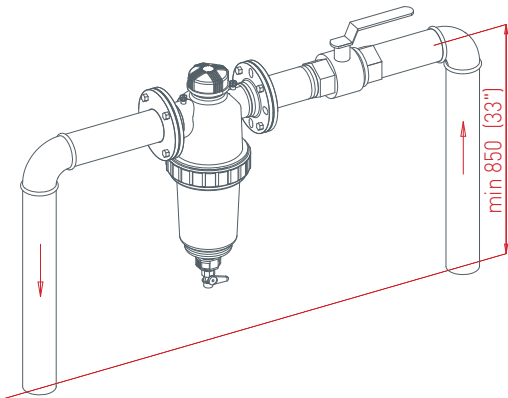

Dim. in mm (inch)

*Approx. length required for maintenance

Engineering Data

Filter Type	2" T	2" T-S	3" T	3" LT-S
-------------	------	--------	------	---------

Filter Element Data				
Filter area	Screen = 465 cm ² [72 in ²] Discs = 790 cm ² [122 in ²]	Screen = 700 cm ² [108 in ²] Discs = 1185 cm ² [184 in ²]	Screen = 700 cm ² [108 in ²] Discs = 1185 cm ² [184 in ²]	Screen = 930 cm ² [145 in ²] Discs = 1580 cm ² [245 in ²]
Filter Element type	Weave Wire Screen, Perforated Screen, Disc Element			

*Construction Materials				
Filter housing	Polyamide + Glass Fibers			Polyacetal
Filter Lid	Polyamide + Glass Fibers			Polyacetal
Tightening nut	Polyamide + Glass Fibers			Polyacetal
Clamp	N/A			St. St.
Housing seal	NBR			
Screen	Construction = Polypropylene + Glass Fibers		Mesh = St. St.	Seals = NBR
Discs	Construction = Polypropylene		Grooved discs = polyethylene	Seals = NBR

* Amiad offers a variety of construction materials. Consult us for specifications.

1" Super

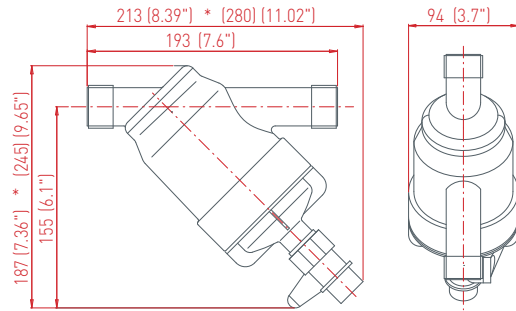

1½" Compact

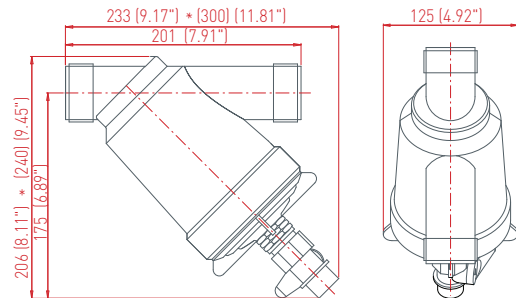

1½" Super

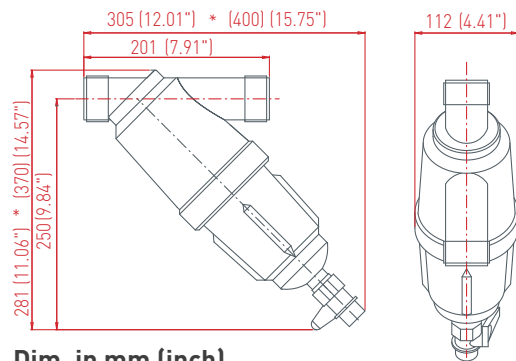

Dim. in mm (inch)

*Approx. length required for maintenance

Technical Specifications

Filter Type	1" Super	1½" Compact	1½" Super
General Data			
Maximum flow rate*	7 m ³ /h (31 US gpm)	15 m ³ /h (66 US gpm)	15 m ³ /h (66 US gpm)
Inlet/Outlet diameter	1" (25 mm)	1½" (40 mm)	1½" (40 mm)
Standard filtration degrees	800, 500, 300, 250, 200, 130, 100, 80, 50, 25, 22 micron		
Max. working pressure	10 bar (145 psi)		
Working temperature range	60°C (140°F)		
Weight [empty]	Screen = 0.52 kg (1.14 lb) Discs = 0.63 kg (1.38 lb)	Screen = 0.76 kg (1.67 lb) Discs = 0.86 kg (1.89 lb)	Screen = 1.0 kg (2.2 lb) Discs = 1.2 kg (2.64 lb)

* Consult Amiad for optimum flow depending on filtration degree & water quality.

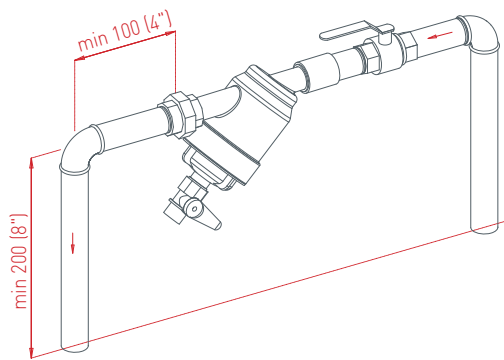

Pressure Loss Graphs

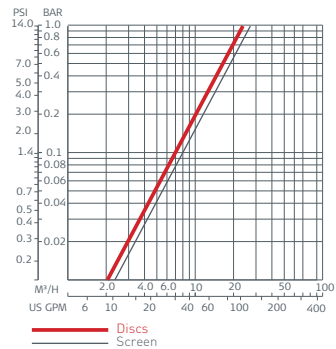
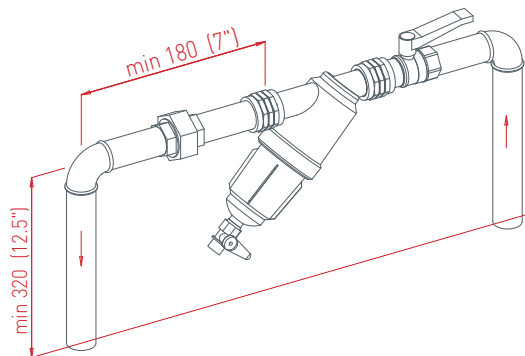
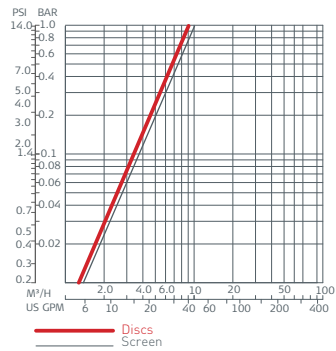
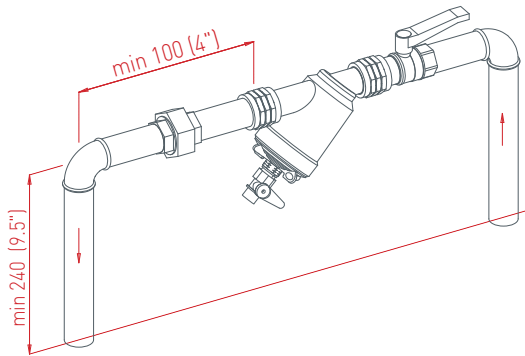
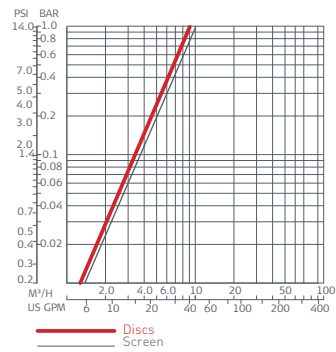

Dim. in mm (inch)

Filter Type	1" Super	1 1/2" Compact	1 1/2" Super
-------------	----------	----------------	--------------

Filter Element Data			
Filter area	Screen = 170 cm ² [26.3 in ²] Discs = 200 cm ² [31 in ²]	Screen = 170 cm ² [26.3 in ²] Discs = 200 cm ² [31 in ²]	Screen = 340 cm ² [52.7 in ²] Discs = 460 cm ² [71.3 in ²]
Filter Element type	Nylon Screen, Weave Wire Screen, Disc Element		

* Construction Materials	
Filter housing	Polyacetal
Filter Lid	Polyacetal
Housing seal	NBR
Screen	Construction = Polypropylene Mesh = St. St. or Polyester Seals = NBR
Discs	Construction = Polypropylene Grooved discs = Polyethylene Seals = NBR

3/4"

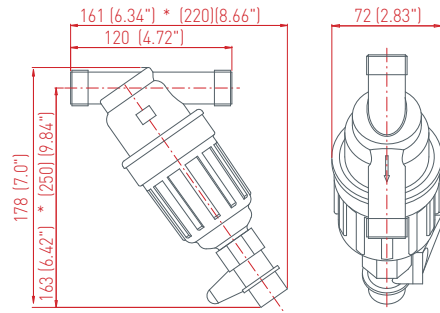

1" Compact

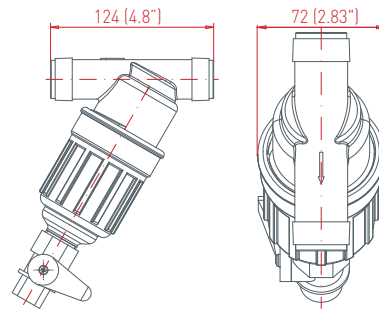

3/4", 1" Compact w/o valve

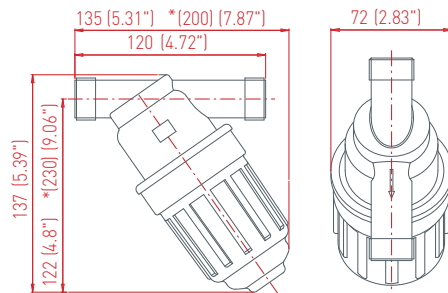

Dim. in mm (inch)

*Approx. length required for maintenance

Technical Specifications

Filter Type	3/4"	1" Compact
General Data		
Maximum flow rate*	3 m ³ /h (13.2 US gpm)	5 m ³ /h (22 US gpm)
Inlet/Outlet diameter	3/4" (20 mm)	1" (25 mm)
Standard filtration degrees	800, 500, 300, 200, 130, 100, 80, 50, 22 micron	
Max. working pressure**	10 bar (140 psi)	
Working temperature range	60°C (140°F)	
Weight [empty]	Screen = 0.28 kg (0.61 lb)	Screen = 0.30 kg (0.66 lb)

* Consult amiad for optimum flow depending on filtration degree & water quality.

** Chemical resistant filters are rated to 8 bar.

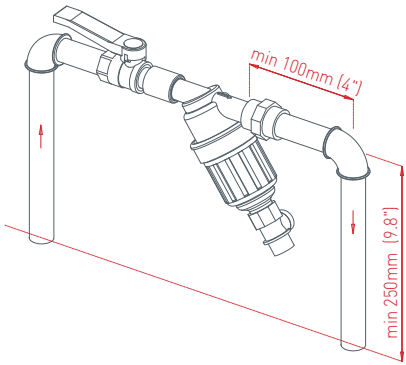

Pressure Loss Graphs

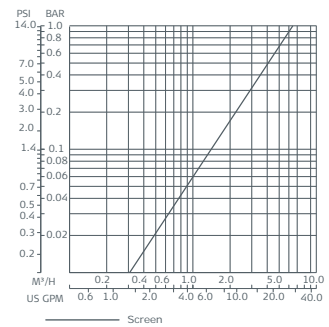
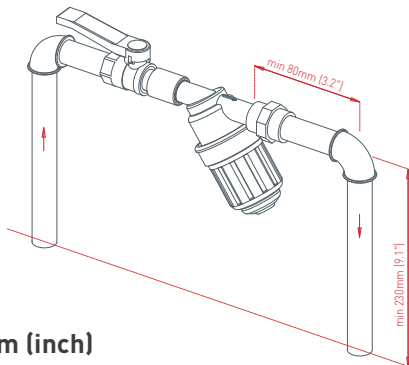
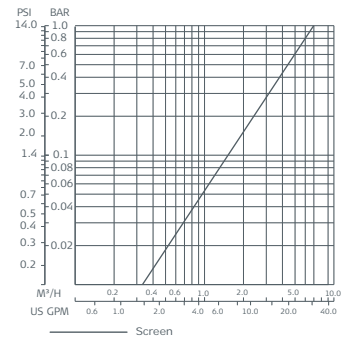
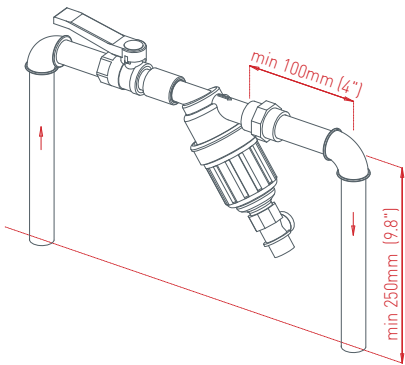
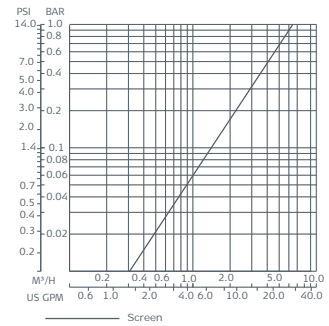

Dim. in mm (inch)

Filter Type	¾"	1" Compact
-------------	----	------------

Screen Data		
Filter area	Screen = 110 cm ² [17 in ²]	Screen = 110 cm ² [17 in ²]
Screen types	Nylon Screen, Weave Wire Screen	

Filter Type	¾" and 1"	¾" and 1" Chemical resistant
-------------	-----------	------------------------------

* Construction Materials		
Filter housing	Polyacetal	Polypropylene
Filter Lid	Polyacetal	Polypropylene
Housing seal	NBR	Viton or NBR
Screen	Construction = Polypropylene Mesh = St. St. or Polyester Seals = NBR	Construction = Polypropylene Mesh = St. St. or Polyester Seals = Viton or NBR

* Amiad offers a variety of construction materials. Consult us for specifications.



Municipal



Industry



Irrigation

Headquarters

Amiad Water Systems Ltd. D.N. Galil Elyon 1, 12335, Israel,
Tel: 972 4 690 9500, Fax: 972 4 690 9391,
E-mail: info@amiad.com

North America

Amiad Filtration Systems, 2220 Celsius Avenue, Oxnard,
California 93030, USA, Tel: 1 805 988 3323, Fax: 1 805 988 3313,
E-mail: info@amiadusa.com

South America

Amiad Oil & Gas, Benito Nardone 2219, Montevideo, Uruguay,
Tel: 598 2 7117617, Fax: 598 2 7120816,
E-mail: amisur@adinet.com.uy

Chile

Amiad Andina, Carretera General San Martín 16.500 No 30,
Loteo Industrial Los Libertadores, Colina, Santiago de Chile,
Tel: 56 2 489 5100, Fax: 56 2 489 5101,
E-mail: amiadandina@amiad.com

Brazil

E-mail: amiad@amiad.com.br

Europe

Amiad Water Systems Europe SAS, Ilot No4 ZI La Boitardière,
37530 Chargé, Tel: 33 (0) 2 47 23 01 10, Fax: 33 (0) 2 47 23 80 67,
E-mail: info@amiadfrance.com

Germany

Amiad Filtration Solutions (2004) Ltd. Zweigniederlassung
Deutschland Prinz-Regent-Str. 68 a 44795 Bochum,
Tel: 49 (0) 234 588082-0, Fax: 49 (0) 234 588082-12,
E-mail: info@amiad.de

Turkey

FTS – Filtration & Treatment Systems, Istanbul yolu 26 Km,
Yurt Orta Sanayii, Saray, Ankara, Tel: 90 312 8155266/7,
Fax: 90 312 8155248, E-mail: info@fts-filtration.com

India

Amiad Filtration India Pvt Limited, 305 Sai Commercial Building
Govandi St Rd, Govandi Mumbai 400 088, Tel: 91 22-67997813/14,
Fax: 91 22-67997814, Email: info@amiadindia.com

China

Yixing Taixing Environtec Co., Ltd. 70 Baihe Chang, Xingjie Yixing
Jiangsu, 214204, Tel: 86 510 87134000, Fax: 86 510 87134999,
E-mail: marketing@taixing.cc

South-East Asia

Filtration & Control Systems Pte. Ltd., 19B Teo Hong Road,
088330 Singapore, Tel: 65 6 337 6698, Fax: 65 6 337 8180,
E-mail: fcs1071@pacific.net.sg

Australia

Amiad Australia Pty Ltd. 138 Northcorp Boulevard,
Broadmeadows, Victoria 3047,
Tel: 61 3 93585800, Fax: 61 3 93585888,
E-mail: sales@amiad.com.au

www.amiad.com

NP.00942/10.2011

