

REV	REVISION DESCRIPTION	LOG NO.	REV BY	CHK BY	APPROVAL AND DATE
A	DRAWING RELEASED		TPH		TPH 2023-08-25

NOTES:

- 1. INLET PORT: 1" FEMALE NPT
- 2. OUTLET PORT: 1" MALE NPT
- 3. ASSEMBLY IS REVERSABLE. LEFT SIDE INLET SHOWN
- 4. DIMENSIONS ARE FOR REFERENCE ONLY AND SUBJECT TO CHANGE WITHOUT NOTICE

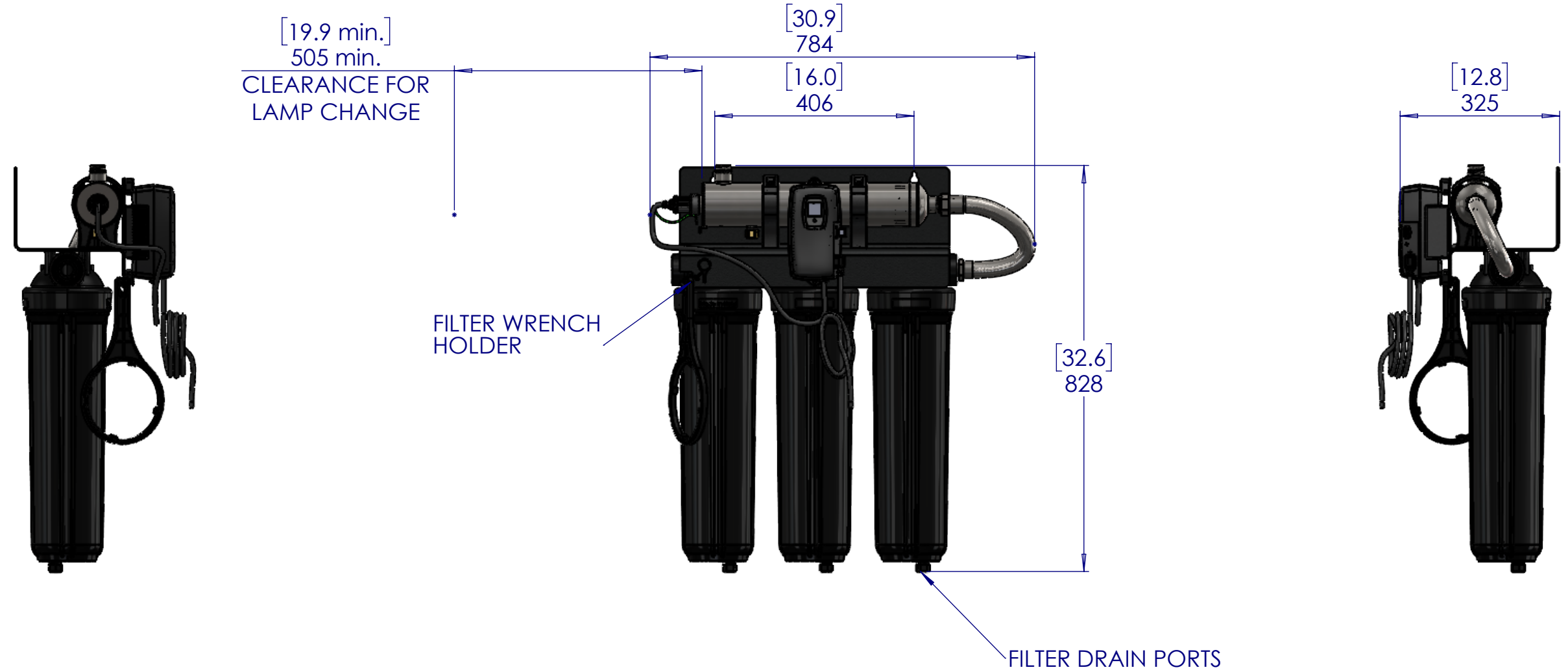
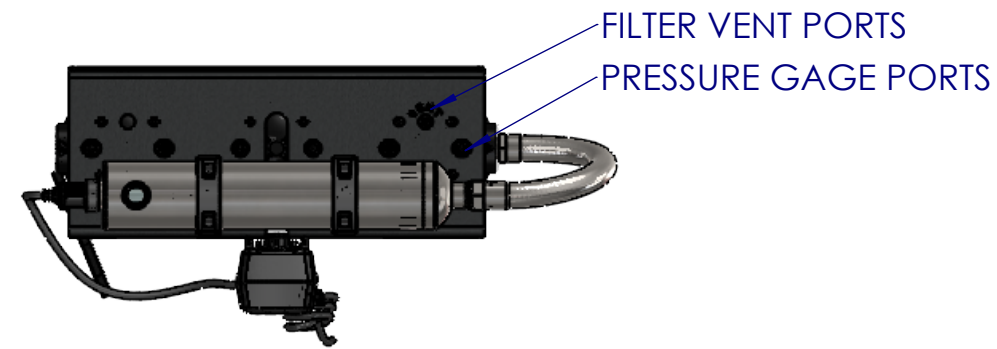

UNLESS OTHERWISE SPECIFIED:
 DIMENSIONS ARE IN MM. [INCHES]
 IN SQUARE BRACKETS
 TOLERANCES: 0-6 mm ±0.1 mm
 6-30 mm ±0.2 mm
 >30 mm ±0.5 mm
 REMOVE ALL BURRS
 ALL CORNERS R 0.25 OR BREAK
 ▽- CRITICAL DIMENSION

LUMINOR
ENVIRONMENTAL

COPYRIGHT 2012 BY LUMINOR ENVIRONMENTAL INC., GUELPH, ONTARIO, CANADA.
 ALL RIGHTS RESERVED. NO PART OF THIS DOCUMENT MAY BE REPRODUCED,
 STORED IN A RETRIEVAL SYSTEM, OR TRANSMITTED IN ANY FORM, WITHOUT THE
 WRITTEN PERMISSION OF LUMINOR ENVIRONMENTAL INC.

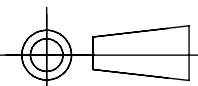
DESCRIPTION: TRIPLE RACK WITH UV INSTALLATION DIMS		PART NO. LBH5-Z222	REV
 THIRD ANGLE PROJECTION	SCALE: 1:20		A
		SHEET 2 OF 2	SIZE: B

DWG. NO.

D
C
B
A