

## RAIN HARVESTING

by Blue Mountain Co

# Maelstrom™



### KEY BENEFITS

1. A single point, tank-top filter with a ground breaking U-shaped design.
2. The 180 micron filter screens particles 5 times smaller than is achieved with a standard tank screen.
3. Reduces the hassle of cleaning leaf and debris build-up through Self-flushing.
4. Blocks out light that supports algae growth.
5. Is a versatile product, able to be installed in a variety of pre-tank locations.
6. Reduces frequency and cost of tank cleaning by lowering common sediment build up through cleaner tank water.

### HOW IT WORKS

1. Rainwater enters the Maelstrom through either of the horizontal-facing couplings.
2. The rainwater then enters the Primary Filter (**J**). The unique curved filter slows the velocity of the water by changing the direction of it's flow.
3. Surrounding the Primary Filter is a Secondary Filter (**C**), comprising of a nylon mesh bag which filters fine particulates larger than 180 micron. This filter assembly is easily removable and will require periodic maintenance.
4. The filtered rainwater then continues to move through the Maelstrom to the Filtered Water Outlet (**F**) and into the rainwater tank or pipe (if attached).

# Installation Types

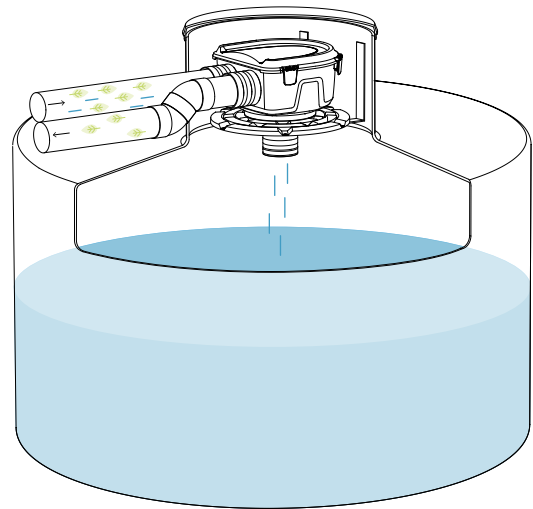
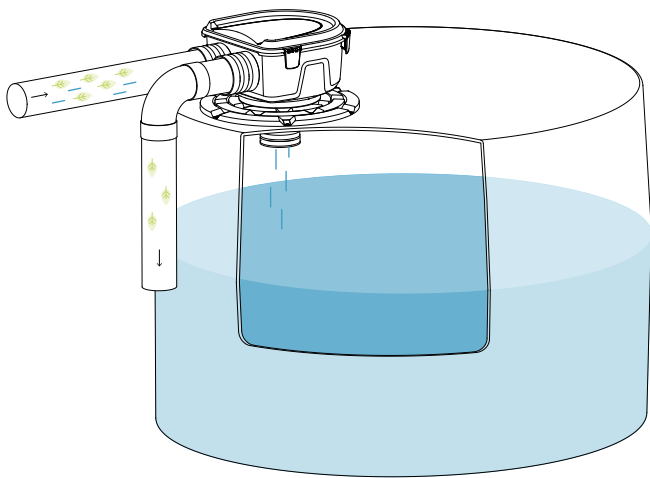

## TANK TOP

1. Remove the existing tank screen from the opening of your rainwater tank.
2. If required trim the Mounting Plate (**G**) to the nearest size to the removed tank screen by turning it upside down.
3. It is important that after the Mounting Plate is cut, the screw points will still allow you to screw through the Mounting Plate into the top of the tank, to provide a mosquito proof seal.
4. Fasten the Mounting Plate to tank using screws supplied.
5. Measure and cut the length of the inlet and outlet pipes so that the pipe will fit within the flexible Inlet (**I**) and Waste Outlet (**H**) couplings.
6. Fit the Maelstrom to the Mounting Plate and connect the Inlet and Waste Outlet to the pipework.

## IN-TANK

1. Check that the Maelstrom (including flexible couplings) and Mounting Plate (**G**) will fit within the riser of the tank. Leave enough space to allow the clips on the lid to open, and for the inlet and outlet pipes to be connected to the Maelstrom.
2. Identify the location of any existing inlets through the riser and use this to determine the height where the Maelstrom will be positioned.
3. Select the appropriate brackets which will support the Maelstrom and install them at least 260mm/10.24" apart to ensure enough clearance around the Maelstrom outlet.
4. Mark where the waste outlet hole will be located on the tank riser and create the hole as required.
5. Screw the Mounting Plate to the brackets.
6. Install the Maelstrom into the hole of the Mounting bracket.
7. Select and install the inlet (**I**) and waste outlet (**H**) pipe.

## TOOLS REQUIRED

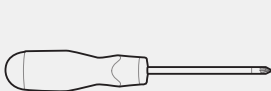

SCREWDRIVER

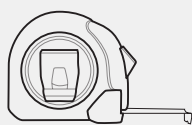

TAPE MEASURE



UTILITY KNIFE



MARKER PEN

## OVERFLOW OPTIONS

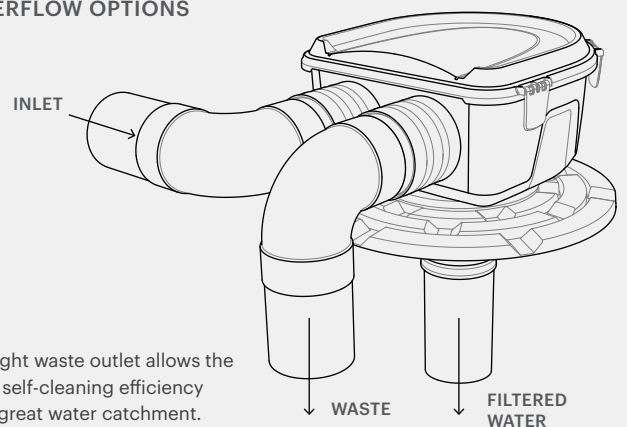

Straight waste outlet allows the best self-cleaning efficiency and great water catchment.

WASTE

FILTERED WATER

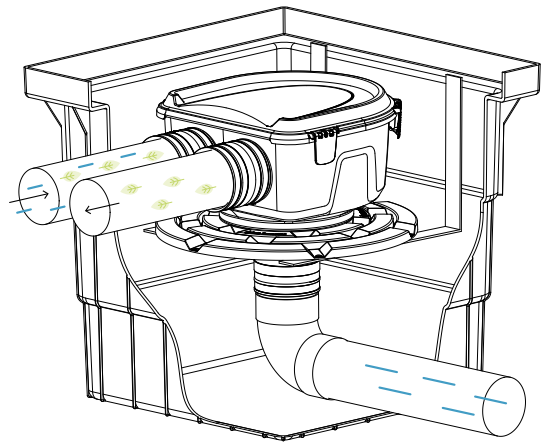
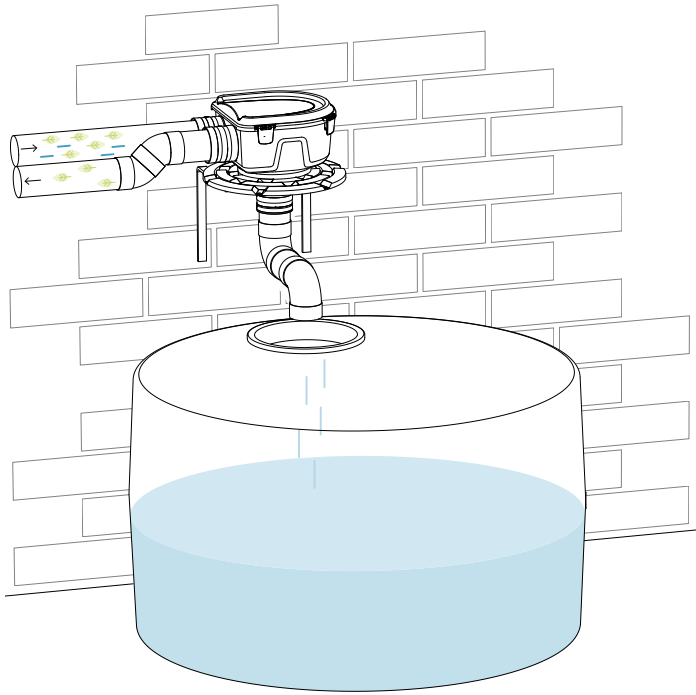

#### WALL MOUNTED

1. Select an appropriate bracket that can support the whole Mounting Plate **(G)**.
2. Install the brackets at least 260mm/10.24" apart to ensure there is enough clearance for the Maelstrom outlet.
3. Screw the Mounting Plate to the brackets ensuring that it is centred.
4. Fit the Maelstrom to the Mounting Plate.
5. Select and install the Inlet **(I)** and Outlet **(H)** pipe.
6. Install the filter water pipe **(F)**

#### STORMWATER PIT

Also suitable for in-ground installations where the inlet of the tank is lower than the outlet of the stormwater pit.

1. Check that the Maelstrom (including flexible couplings) and Mounting plate **(G)** fit within the pit. Allow space for the clips on the lid to open.
2. Using a hole-saw, cut the filtered water outlet at the base of the stormwater pit.
3. Insert filtered water pipe and attach a 90° bend to the pipe. Attach flexible coupling **(F)** to the bend and slide the Maelstrom onto the coupling.
4. Use a hole saw to cut holes in the pit to align with the Inlet **(I)** and Waste outlet **(H)**.
5. Add a support (eg. Bracket) to the underside of the Maelstrom if it requires stabilising.
6. Insert Inlet and Waste pipes through the holes, and tighten all flexible couplings.
7. Apply sealant around any penetrations made to the pit (around pipes, for example) to seal the unit.

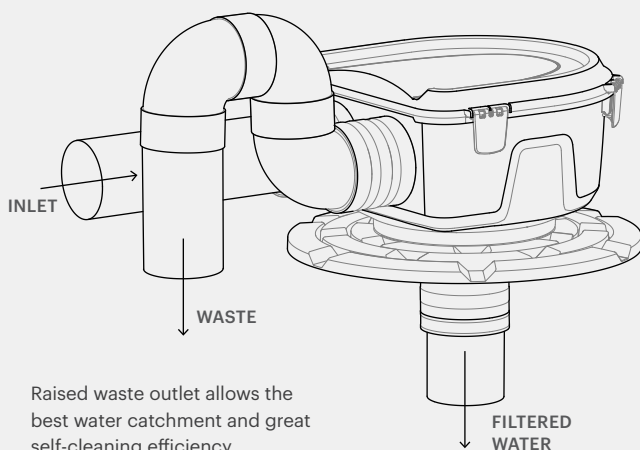

Raised waste outlet allows the best water catchment and great self-cleaning efficiency.

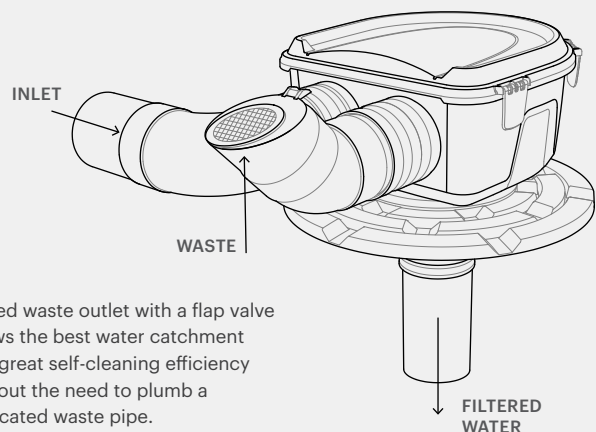

Raised waste outlet with a flap valve allows the best water catchment and great self-cleaning efficiency without the need to plumb a dedicated waste pipe.

## MAINTENANCE

Maintenance frequency depends on the environment in which the product is installed. For example, high debris areas will require more regular maintenance. It is recommended to perform an initial inspection of the filter and bag after the first rainfall event to gauge how frequently maintenance will be required.

## TO CLEAN

1. Unlatch and remove Lid (A)
2. Grasp Handle (K) and lift filter upward to remove
3. Release the 4 Handle clips, slide the handle off the filter and remove the Secondary Filter (C).
4. Wash out and clean Secondary Filter. Use a brush if needed to remove debris.
5. Lift Mosquito Proof Screen (D) out and clean debris from both sides of screen.
6. Replace Mosquito Proof Screen ensuring it sits securely in place.
7. Replace Secondary Filter and secure with Handle.
8. Return Primary Filter back into position within Filter Housing (E).
9. Replace Lid and secure Latches (B)

## MOSQUITO SCREENING

For effective mosquito screening in tank mounted applications, ensure the following:

1. The Mounting Plate (G) is securely attached to the tank
2. The Filter Housing (E) is clipped securely onto the mounting plate
3. The Mosquito Proof Screen (D) is attached securely to the Filter Housing underneath the Primary Filter (J)

Based in Queensland, Australia, Rain Harvesting Pty Ltd is an expert in rain harvesting system design and construction.

The company's range of rainwater collection, storage, filtration and distribution products are born out of over twenty years hands-on experience in one of the world's most daunting water-management regions.

## RAIN HARVESTING

by Blue Mountain Co

PO Box 1246  
Milton QLD 4064 Australia  
Tel +61 (0)7 3248 9600  
info@rainharvesting.com.au

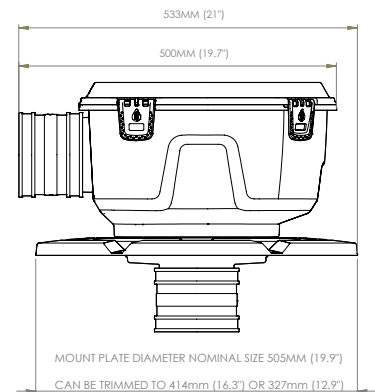
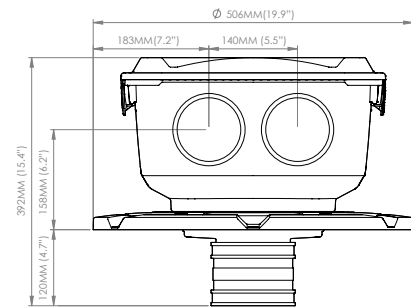
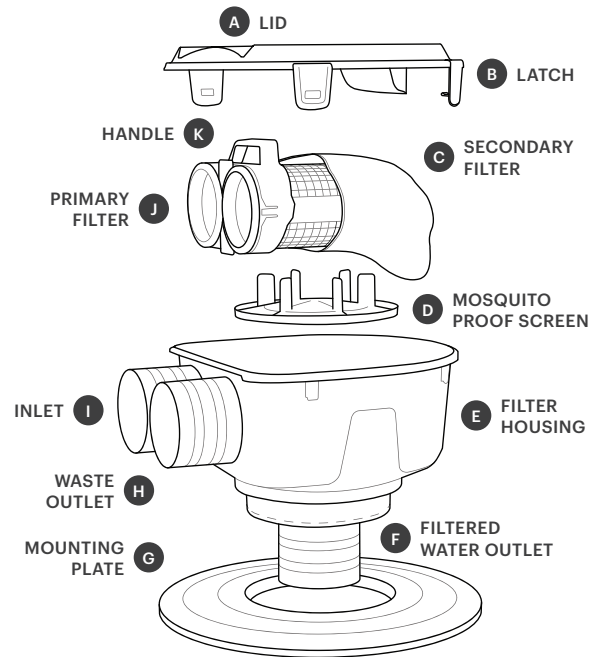

Primary Filter	2mm (0.08") Aperture, Polypropylene
Secondary Filter	0.18mm (180µm) Aperture, Nylon
Mosquito Proof Screen	0.955mm (0.04") Aperture, SS316
Inlet & Outlet Pipe Size	DN100 (110mm OD) / 4" OD
Coupling	Flexible, EPDM
Body & Base Plate	ABS, Polypropylene

## Performance Data

Water Catchment Efficiency @ 5L (1.32gal) / second*	99%
Water Catchment Efficiency @ 10L (2.64gal) / second*	96%

\*For wet/charged system configuration with clean water flow